

* ADJUSTMENT RING CHART

I.D.	HEIGHT	WALL THICKNESS	O.D.	WEIGHT
24"	2"	5"	34"	74 lbs
24"	4"	5"	34"	148 lbs
24"	6"	5"	34"	223 lbs
24"	8"	5"	34"	297 lbs
30"	2"	6"	42"	111 lbs
30"	4"	6"	42"	221 lbs
30"	6"	6"	42"	332 lbs
36"	4"	6"	48"	258 lbs
36"	6"	6"	48"	387 lbs

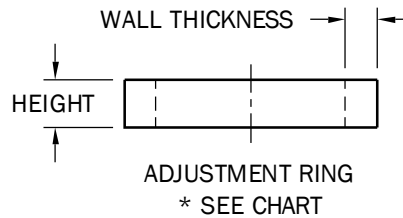
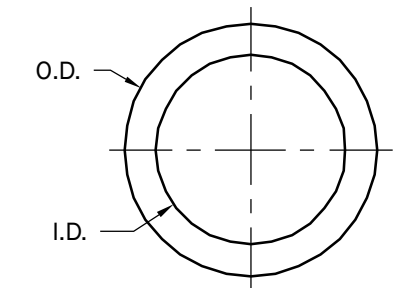

ADJUSTMENT RING
AS NEEDED

CONE
CONCENTRIC

CONE
ECCENTRIC

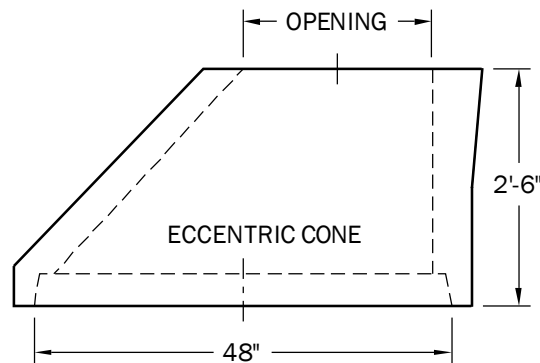
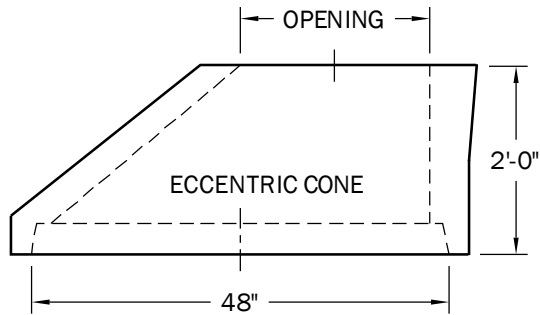
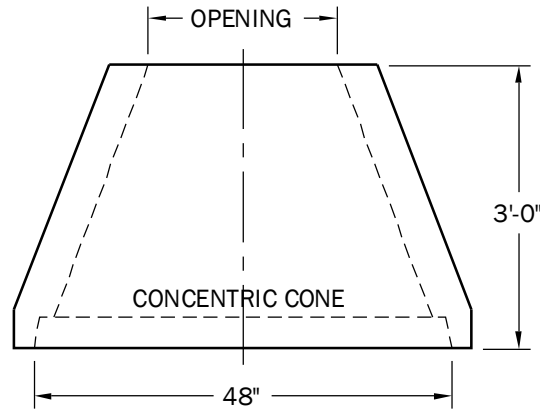
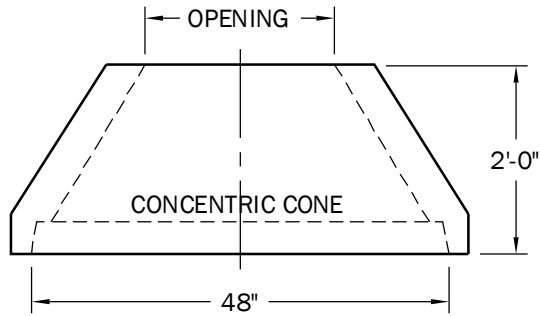

NOTES:

1. OPENING 24" Ø OR 30" Ø
2. CONES FOR 48" I.D. MANHOLES ONLY
3. MINIMUM WALL THICKNESS 4" PER ASTM C - 478

WESTERN
PRECAST CONCRETE INC.
QUALITY PRODUCTS AND SERVICE SINCE 1946

ADJUSTMENT RING & CONES

9101 Roseway

(915) 859-9362